



深圳某些蓝牙模块厂家 三宗罪

1. 割假售假

盗用我们的命名HC，混淆产品。品牌：HC汇承。HC为我司名中“汇承”拼音的首字母大写，只有广州汇承的HC模块才是第一源头正版模块。

2. 欺骗消费者

盗用BQB认证，谎称自己的数传模块经过BQB认证，上传一张看不清的BQB证书坑蒙拐骗。有证书的话绝对不怕清晰放大展示。用户们完全可以向厂家索要BQB完整证书以及检测报告。

3. 盗版横行，山寨到底

抄袭广州汇承蓝牙模块封装及软件烧录程序，山寨硬件，蒙蔽消费者。广州汇承蓝牙模块内的源程序完全是自主研发，被某些深圳无良蓝牙厂家盗取烧录进山寨蓝牙模块中，并盗用我们的产品型号名称出售。

（用户可以对HC-06模块发AT+VERSION指令，返回的是OKlinvorV1.n。ID:linvor为淘宝广州汇承蓝牙模块旗舰店的卖家ID。）

为了广大消费者的切身利益 我们愿意与山寨盗版
无良厂家抗争到底！

————广州汇承信息科技有限公司



正面



正版



盗版

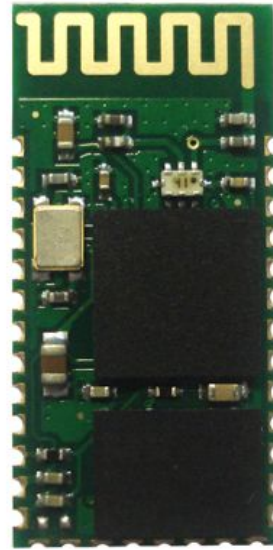

盗版

背面



正版



盗版



广州汇承信息科技有限公司

产品规格书

Rev 1

1.0

DRAWN BY :	Ling Xin	MODEL :	HC-05(主从一体)	
CHECKED BY :	Eric Huang	描述:	BC04 外置 8M Flash 带 EDR 模块	
APPD. BY:	SimonMok			
UART (默认)	9600	蓝牙模块 (含链接)	HC-05、HC-06、HC-08	
		无线模块 (含链接)	HC-11、HC-12	
PIN (默认)	1234	带底板模块 (含连接)	232 TTL接口	HC-05-D、HC-06-D、HC-08-D
			USB 转TTL接口	HC-05-USB、HC-06-USB HC-11-USB
参数架	HC-USB-P			
MODE (默认)	从机		蓝牙适配器	蓝牙适配器

历史版本说明 HC-06 是 LV_BC_2.0 的升级版, wavesen(汇承)曾用名 Linvor(凌峰)



目录

- 1: 产品图片
- 2: 特征
- 3: 引脚定义和功能
- 4: 产品参数和规格
- 5: 参考原理图
- 6: AT 指令集
- 7: 测试数据规格
- 8: 测试方案图表
- 9: 调试设备



产品图片

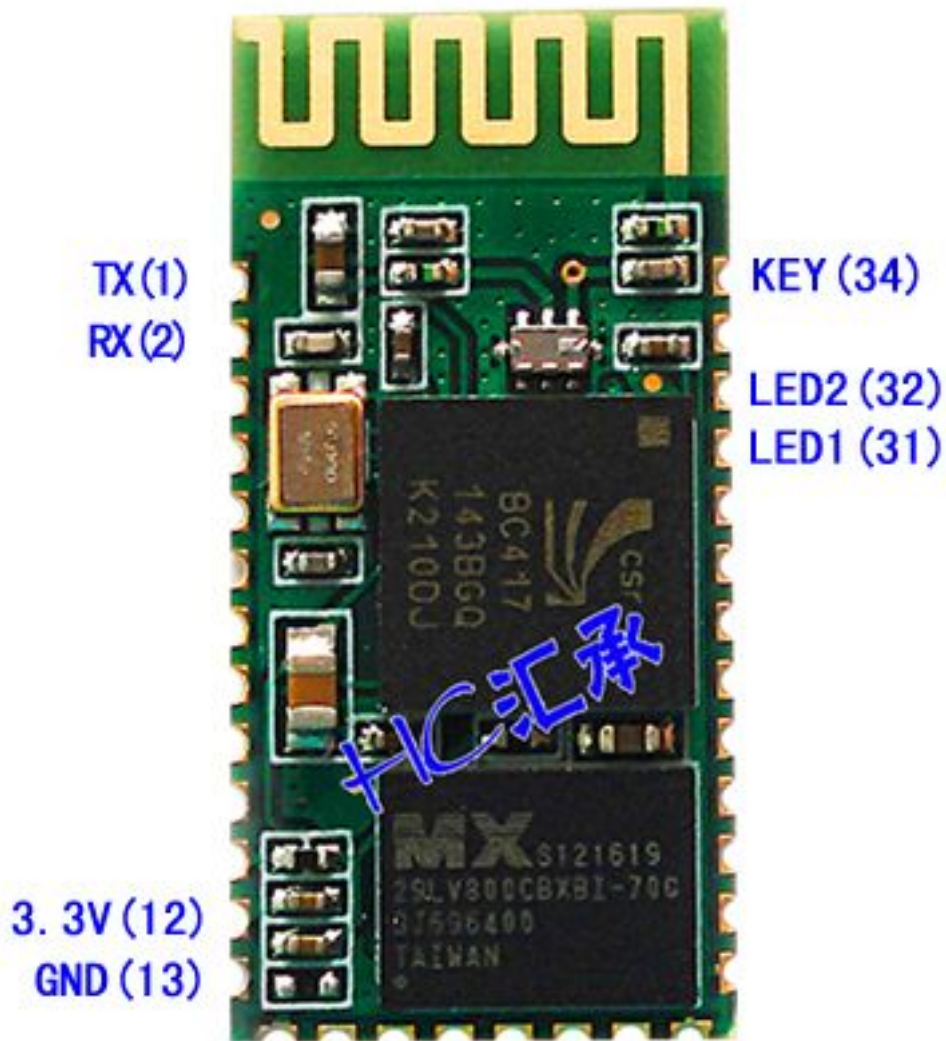

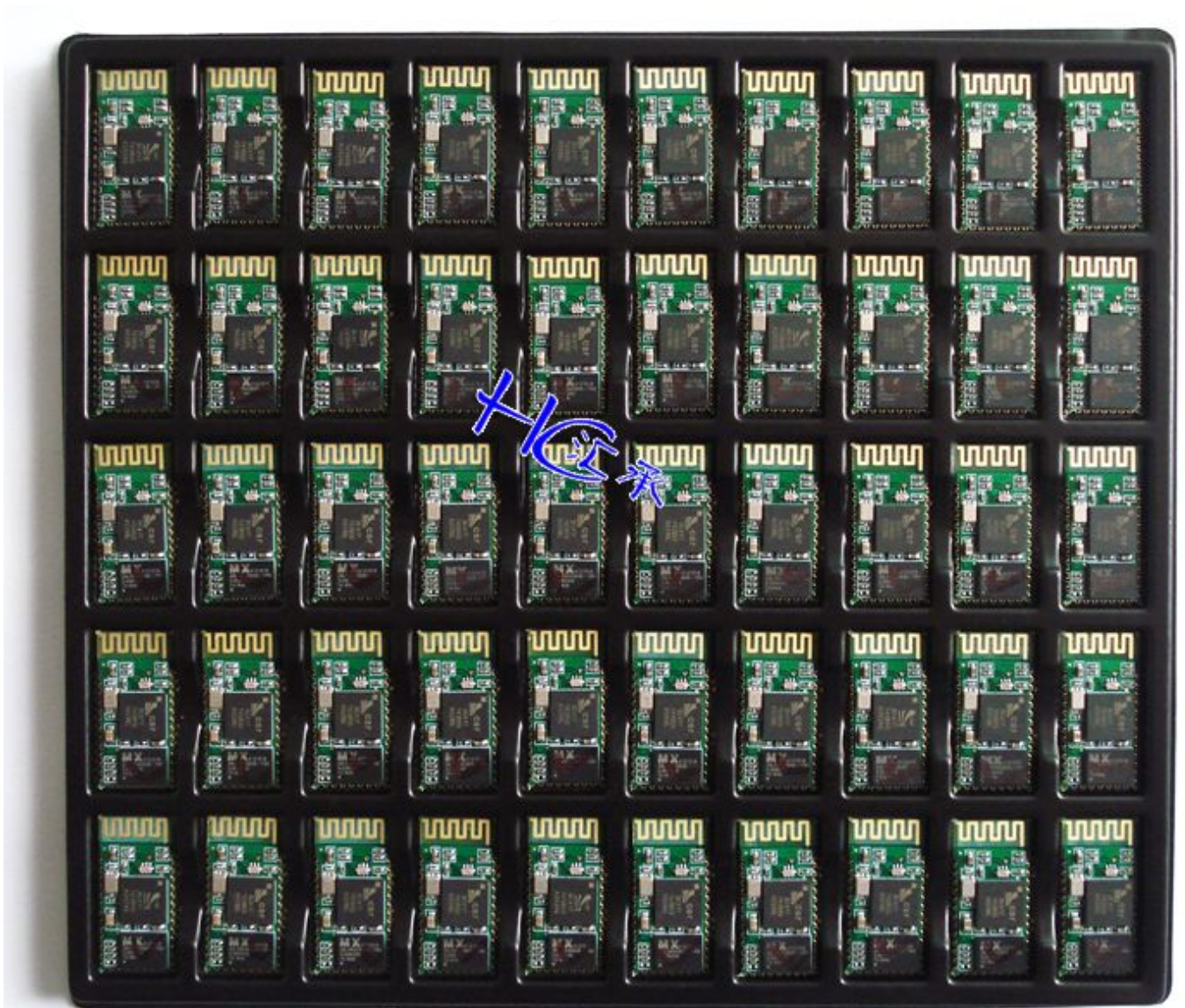



贴片炉温参考

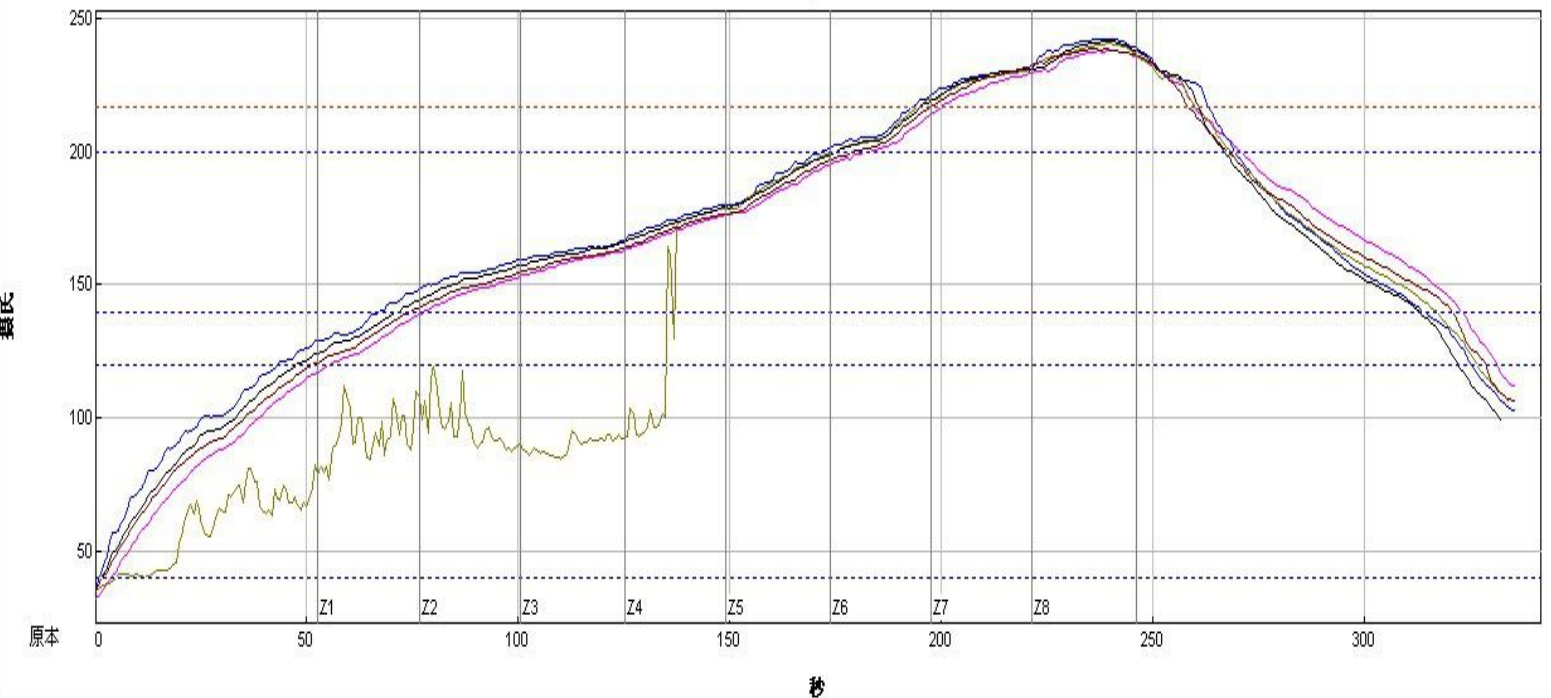

建议首次大批量贴片生产的厂家，先过炉 20~30 片模块，检查炉温是否合适

建议贴片锅炉炉温不得超过参考图温度，二次贴片降低 5 度左右，夏天可以再降低适当温度



特征

无线收发

灵敏度(误码率)达到 -80dBm

$-4 \rightarrow 6\text{dBm}$ 功率可调输出

性能概要 完整的蓝牙解决方案

蓝牙 2.0 带 EDR, 2Mbps-3Mbps 调制度

内置 2.4GHz 天线, 用户无需调试天线

外置 8Mbit FLASH

低电压 3.3V 工作(3.1V~4.2V)不大于50MA (以实测为准)。

可选 PIO 控制

标准 HCI 端口(UART or USB)

USB 协议: Full Speed USB1.1, Compliant With 2.0

模块可以作为 SMD 贴片工艺

RoHS 制程

引脚半孔工艺

数字 2.4GHz 无线收发射

CSR BC04 蓝牙芯片技术

自适应跳频技术

体积小,(27mm×13mm×2mm)

简单的外围设计电路

蓝牙 Class 2 功率级别

存储温度: -40 至 $+85$ 度, 工作温度: -25 至 $+75$

谐波干扰:2.4MHz, 发射功率 3 dBm

误码率:0, 但会在传输链路产生信号衰变, 才有误码, 如 RS232 和 TTL 线路处理线路中

低功耗

高性能无线收发系统



l 低成本

l 应用领域

蓝牙车载免提

蓝牙 GPS

蓝牙 PCMCIA , USB Dongle

蓝牙数据传送

l 软件

CSR

引脚定义和功能

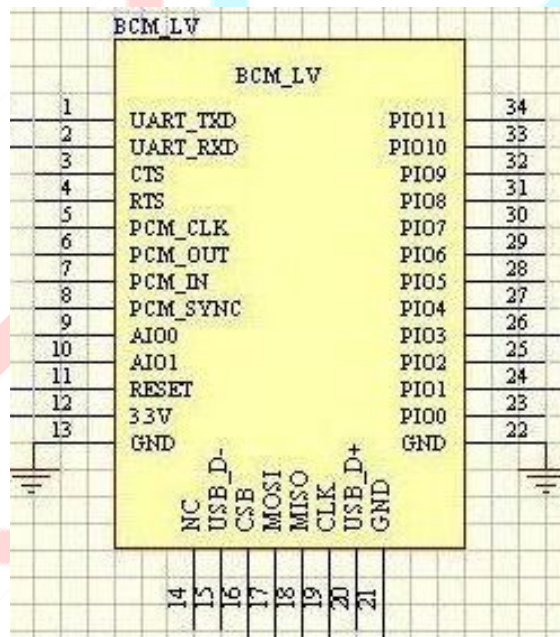

本原理图与实物脚序一致

PIN Name	PIN #	Pad type	Description	Note
GND	13 2	VSS	Ground pot	
1V8	14	VDD	Integrated 1.8V (+) supply with On-chip linear regulator output within 1.7-1.9V	



VCC	12	3.3V		
AIO0	9	Bi-Directional	Programmable input/output line	
AIO1	10	Bi-Directional	Programmable input/output line	
PIO0	23	Bi-Directional RX EN	Programmable input/output line, control output for LNA(if fitted)	

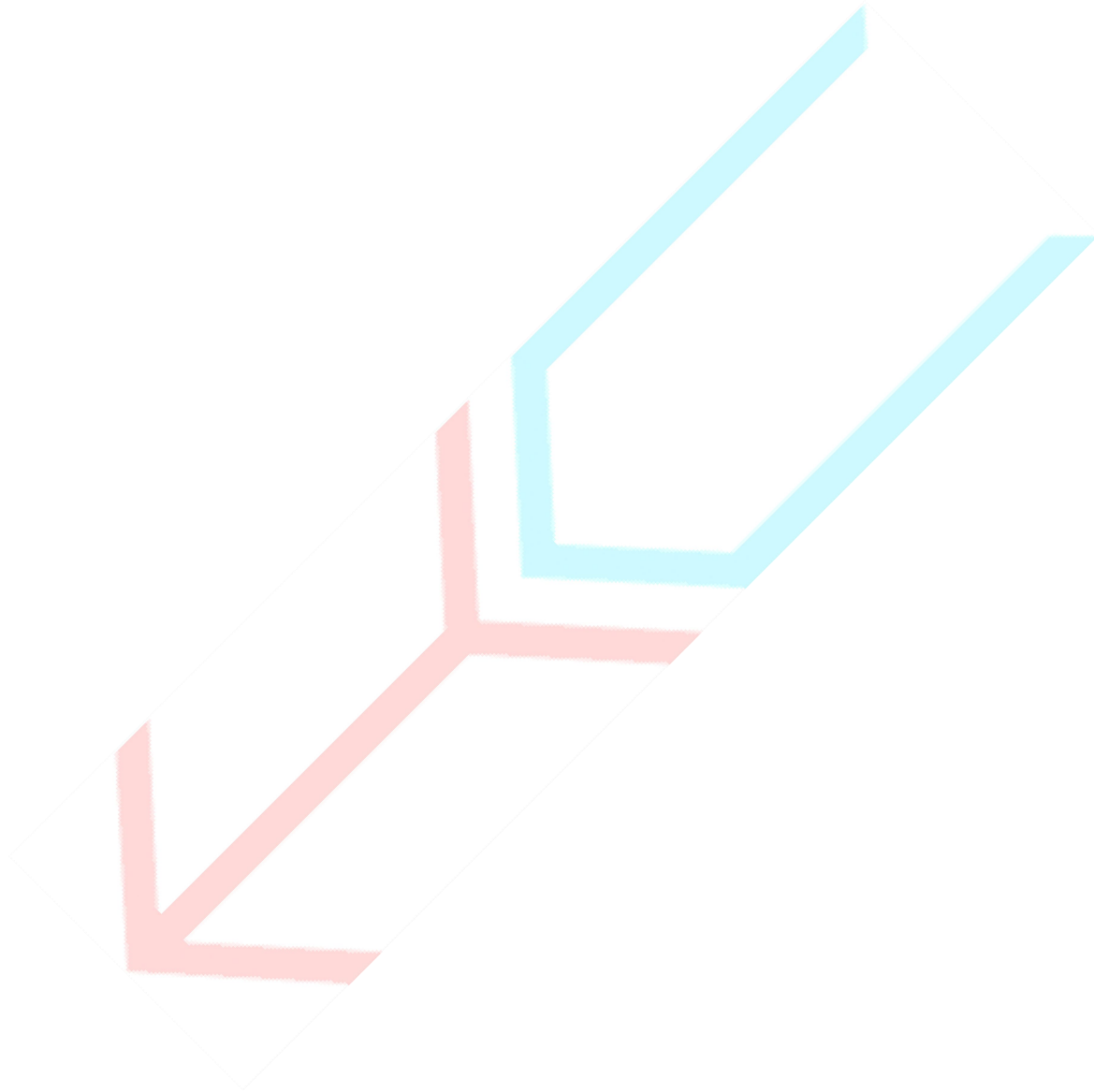



PIO1	24	Bi-Directional TX EN	Programmable input/output line, control output for PA(if fitted)	
PIO2	25	Bi-Directional	Programmable input/output line	
PIO3	26	Bi-Directional	Programmable input/output line	
PIO4	27	Bi-Directional	Programmable input/output line	
PIO5	28	Bi-Directional	Programmable input/output line	
PIO6	29	Bi-Directional	Programmable input/output line	CLK_REQ
PIO7	30	Bi-Directional	Programmable input/output line	CLK_OUT
PIO8	31	Bi-Directional	Programmable input/output line	
PIO9	32	Bi-Directional	Programmable input/output line	
PIO10	33	Bi-Directional	Programmable input/output line	
PIO11	34	Bi-Directional	Programmable input/output line	
RESETB	11	CMOS Input with weak internal pull-down		
UART_RTS	4	CMOS output, tri-stable with weak internal pull-up	UART request to send, active low	
UART_CTS	3	CMOS input with weak internal pull-down	UART clear to send, active low	
UART_RX	2	CMOS input with weak internal pull-down	UART Data input	
UART_TX	1	CMOS output, Tri-stable with weak internal pull-up	UART Data output	
SPI_MOSI	17	CMOS input with weak internal pull-down	Serial peripheral interface data input	
SPI_CSB	16	CMOS input with weak internal pull-up	Chip select for serial peripheral interface, active low	
SPI_CLK	19	CMOS input with weak internal	Serial peripheral interface clock	



		pull-down		
SPI_MISO	18	CMOS input with weak internal pull-down	Serial peripheral interface data Output	
USB_-	15	Bi-Directional		
USB_+	20	Bi-Directional		
1.8V	14		可以外部供电 1.8V	默认为内部供电 1.8V
PCM_CLK	5	Bi-Directional		
PCM_OUT	6	CMOS output		
PCM_IN	7	CMOS Input		
PCM_SYNC	8	Bi-Directional		



产品参数和规格

LINVOR BLUE T

www.linvor.com

Bluetooth Module
 Bluetooth

CSR,BC417143B

V 2.0

2006/09/6

蓝牙 RF 模块

1. 采用 CSR BC4 +8M FLASH 方案
2. 具有 PIO0-PIO11、AIO0、AIO1、
USB、PCM、UART 及 SPI 接口，
模块内置 8MFLASH，功能强大，
用户可定制软件,适用于各种蓝牙
设备，内置 RF 天线,便于调试。

蓝牙协议版本	Bluetooth Specification V2.0 With EDR
USB 协议 USB Protocol	Full Speed USB V1.1 Compliant With USB V2.0
频率	2.4Ghz ISM band
调制方式	GFSK(Gaussian Frequency Shift Keying)
发射功率	-4 ->4 dBm, Class 2
灵敏度	≤ -80dBm at 0.1% BER
通讯速率	Asynchronous:2Mbps(Max)
供电电源	3.3V
工作温度	-20~+55 Centigrade
封装尺寸	27mmX13mmX2mm

也可参考 www.wavesen.com 发布的其他信息



LINVOR BLUE T
www.linvor.com

LV-BC-2.0

单位: mm

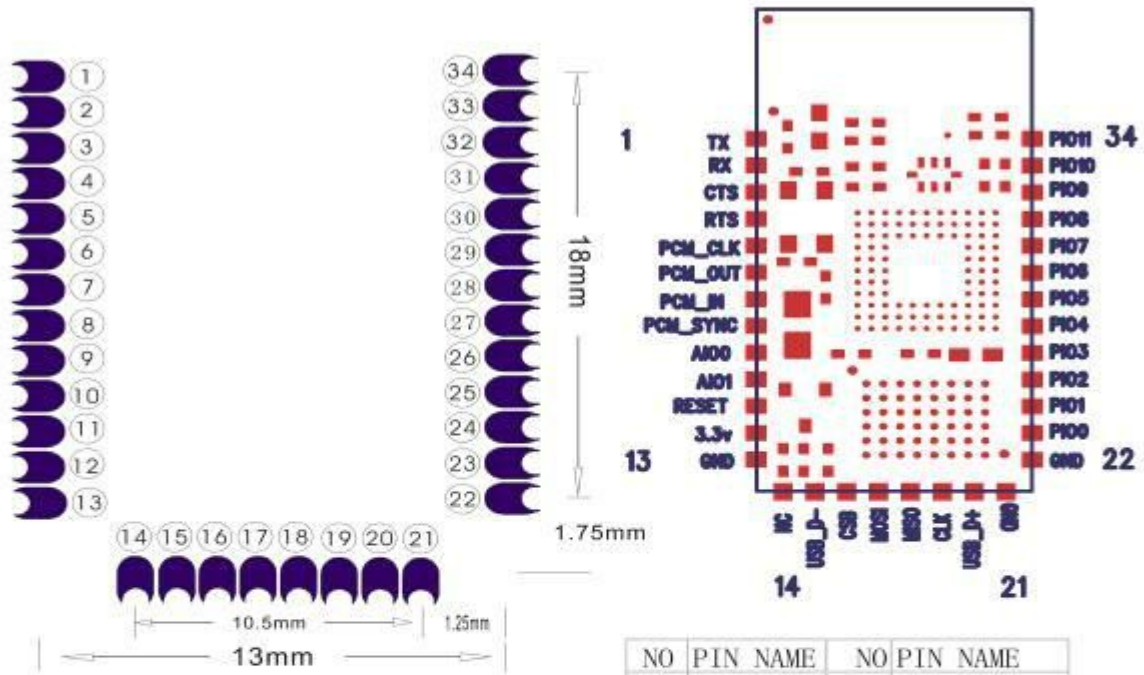

NO	PIN NAME	NO	PIN NAME
1	TX	20	USB D+
2	RX	21	GND
3	CTS	22	GND
4	RTS	23	PI00
5	PCM_CLK	24	PI01
6	PCM_OUT	25	PI02
7	PCM_IN	26	PI03
8	PCM_SYNC	27	PI04
9	AI00	28	PI05
10	AI01	29	PI06
11	RESET	30	PI07
12	3.3V	31	PI08
13	GND	32	PI09
14	NC	33	PI010
15	USB D-	34	PI011
16	CSB		
17	MOSI		
18	MISO		
19	CLK		

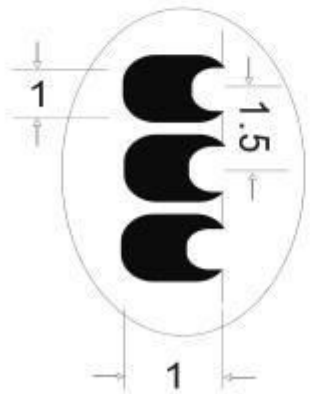

PCB Layout 请参考实物



参考原理图

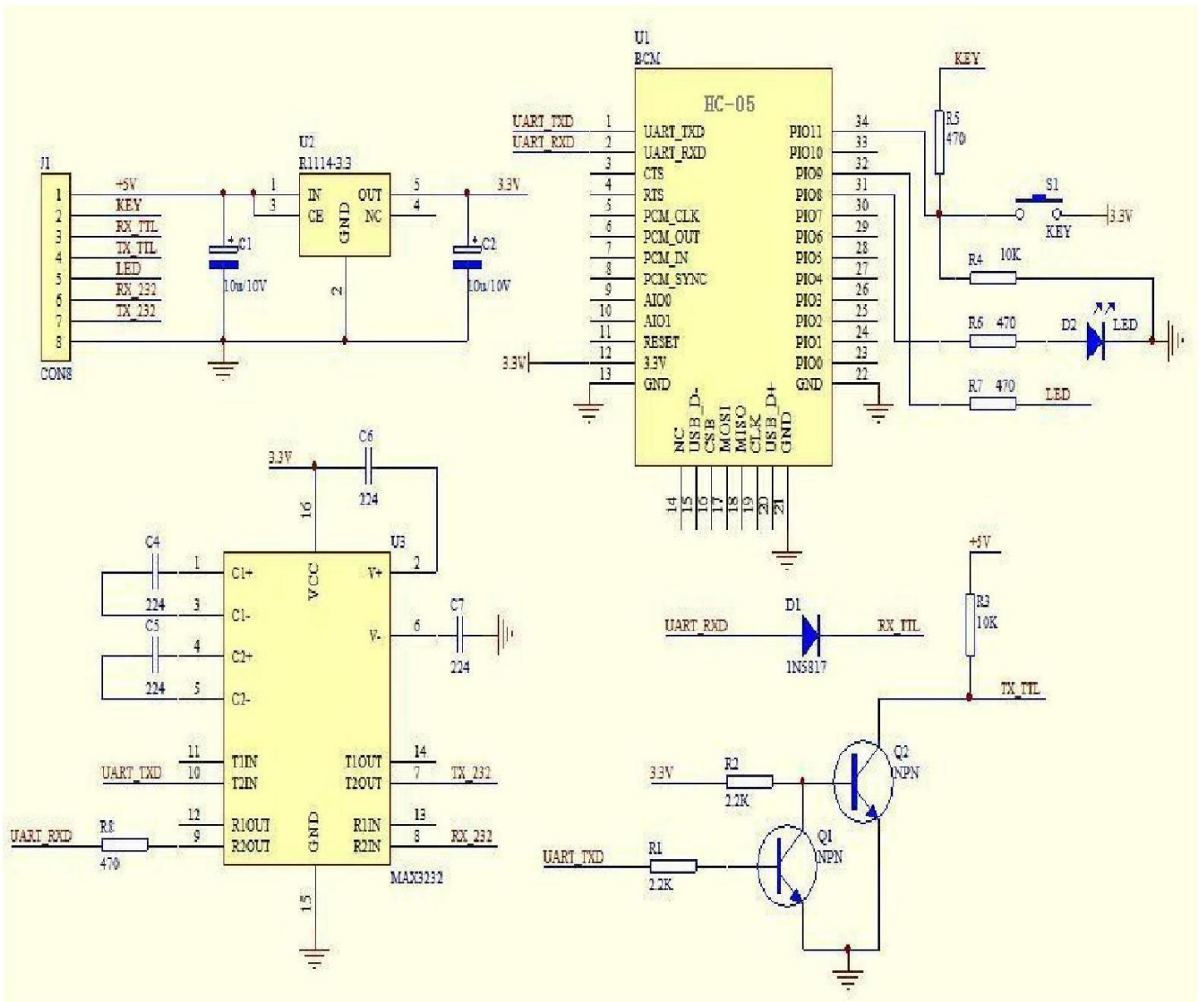

注：蓝牙模块的PIN2：UART-RXD不带上拉，如果单片机TXD无上拉能力的话需要在模块的UART-RXD脚上接个上拉电阻，这个很容易被用户忽略。



对于HC-05 主机而言, WAKEUP 按下后会放弃记忆, 重新搜索新的从机, 如果不放弃记忆, 主机将一直搜索上一次配对过的从机, 直到搜到并配对成功为止, HC-05 的主机有个特性就是记忆最后一次配对过的从机。WAKEUP 对于从机而言没有意义。

AT指令集

因为内容较长, 请参考公司网站下载中心提供的文档:[HC-05蓝牙模块AT指令集](#)

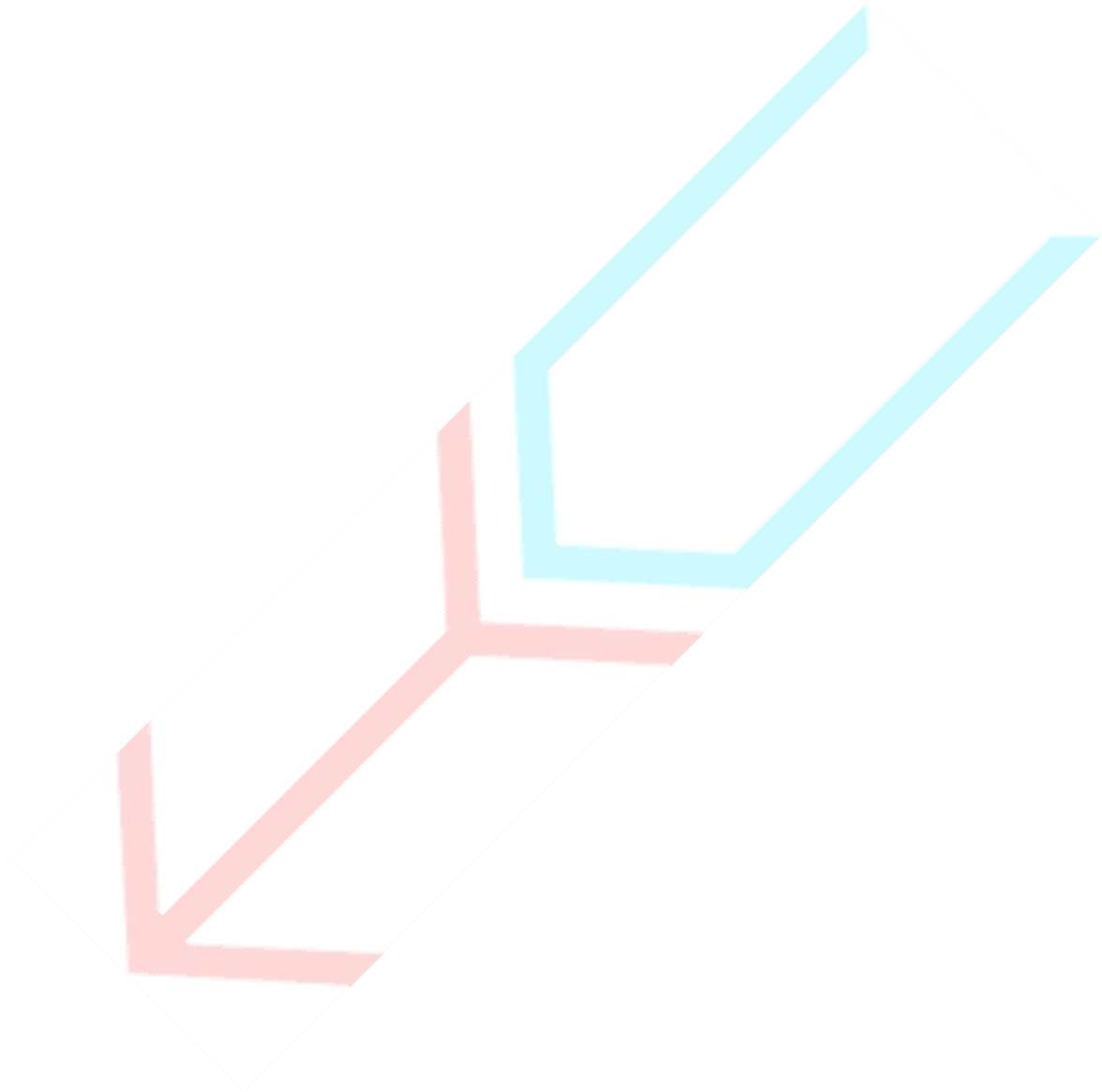



调试设备

9.1 仪器设备

电脑、硬件、3G 频率计 (SP3386)、3.15V DC 电源、屏蔽房、MT8850A (or MT8852B)、蓝牙测试盒。

9.2 软件

7 测试数据规格

		Test Condition 25°C RH 65%			U
		Min	Typ	Max	nit
1	Carrier Freq. (<i>ISM Band</i>)	4		2.4835	M Hz
2	RF O/P Power	6	2	4	dBm
3	Step size of Power control	2		8	dB
4	Freq. Offset (<i>Typical Carrier freq.</i>)	-75		75	KHz
5	Carrier Freq. drift (<i>Hopping on, drift rate/50uS</i>)	-20		20	KHz
	1 slot packet	-25		25	KHz
	3 slot packet	-40		-40	KHz
6	Average Freq. Deviations (<i>Hopping off, modulation</i>)	140		175	KHz
	Freq. Deviation	115			KHz
	Ratio of Freq. Deviation	8			
7	Receive Sensitivity @< 0.1% BER (<i>Bit error rate</i>)	3			dBm

测试方案图表

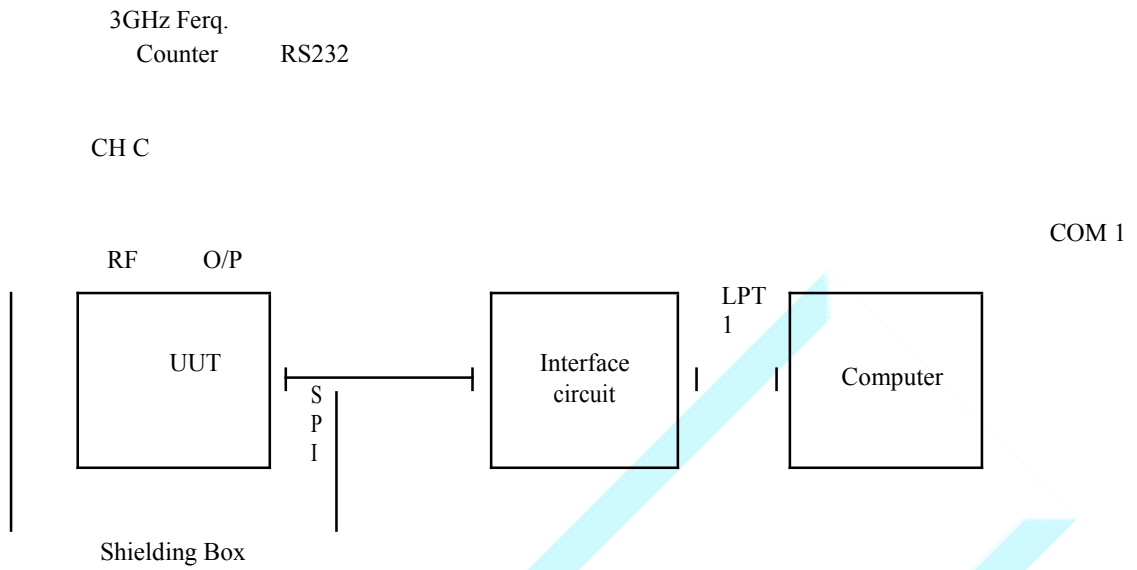

Fig 1. Programming and Freq. Alignment

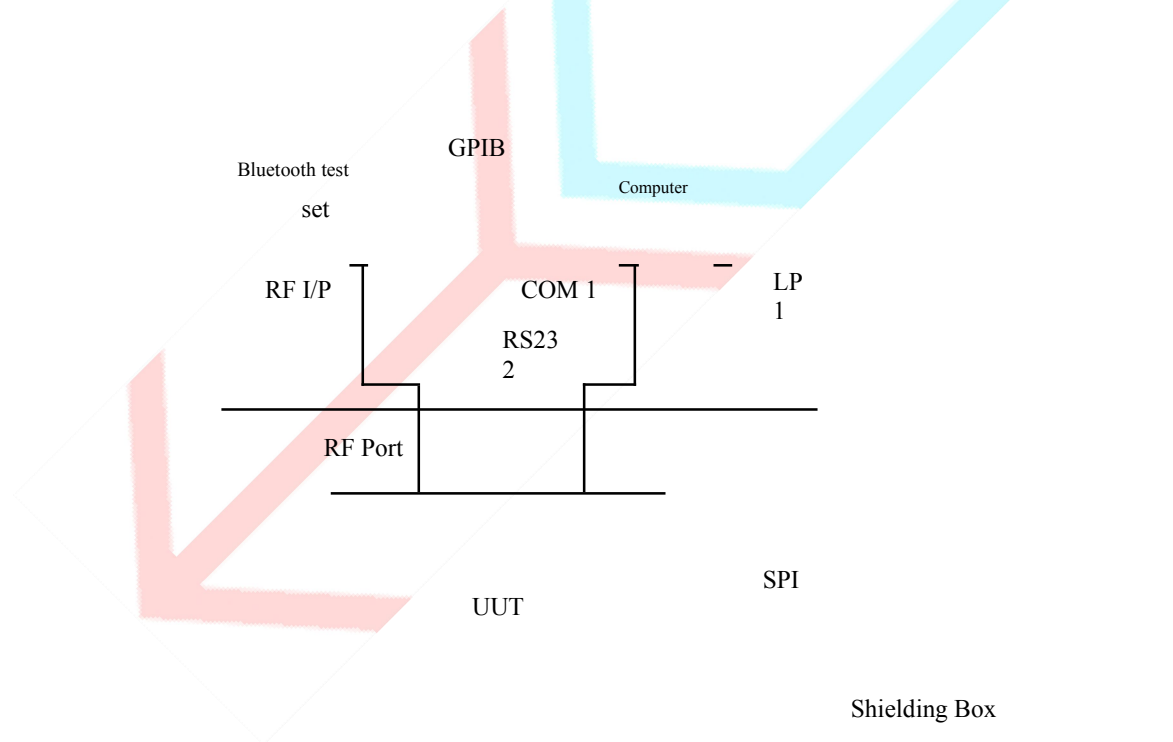

Fig 2 RF parameter Test Procedure

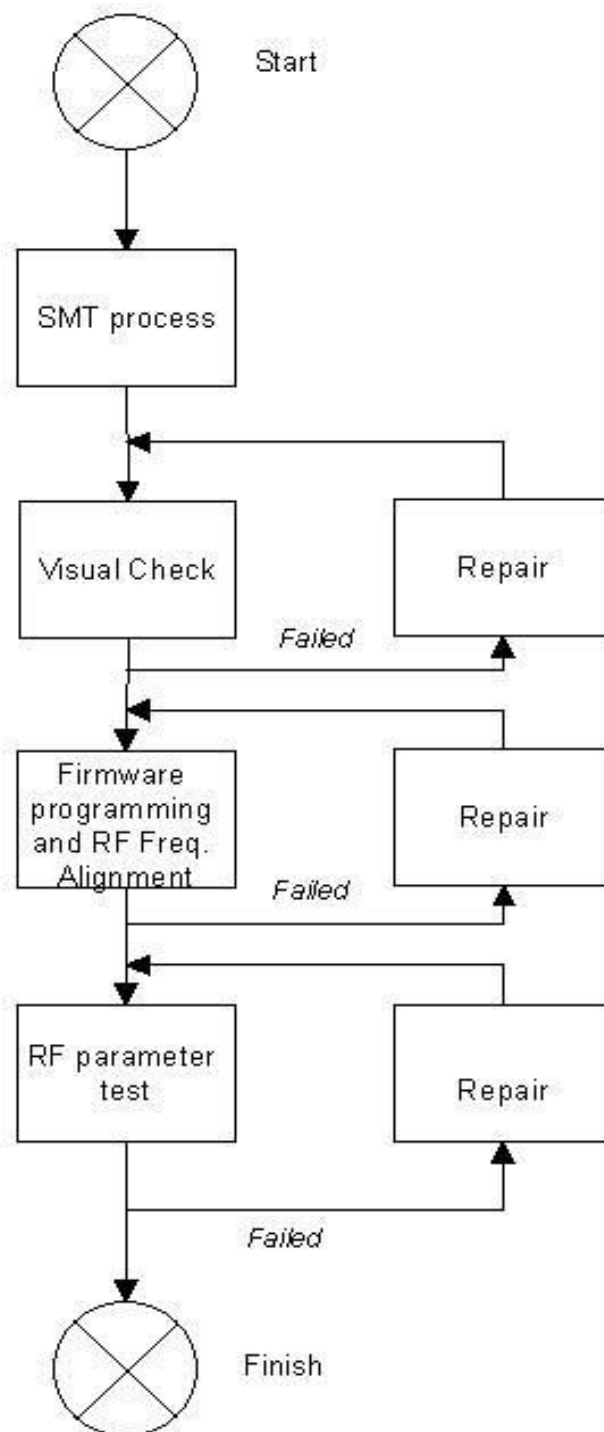

Fig 3 Assemble/Alignment/Testing Flow Chart