



CMOS OV5640C AF Camera Module

1/4-Inch 5-Megapixel Module Datasheet

Rev 1.0, June 2015

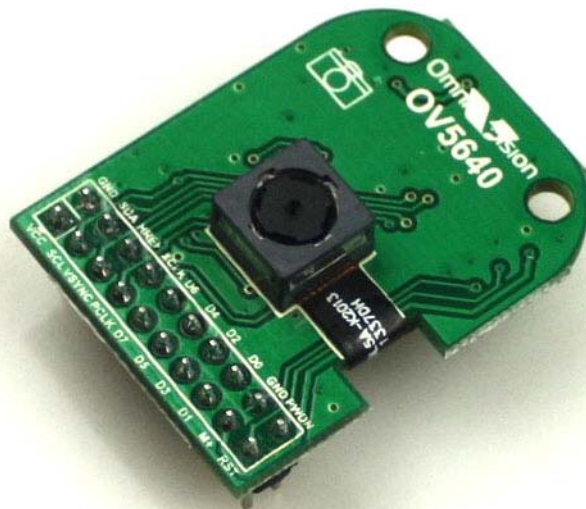

Table of Contents

| | | |
|----------|-----------------------------------|----------|
| 1 | Introduction | 2 |
| 2 | Features | 3 |
| 3 | Key Specifications | 3 |
| 4 | Block Diagram | 4 |
| 5 | Application | 4 |
| 6 | Product Pictures | 5 |
| 7 | Pin Definition | 6 |
| 8 | Mechanical Dimension | 8 |

1 Introduction

ArduCAM now released a new 5MegaPixel AutoFocus CMOS camera module with JPEG output. The camera module is based on Omnivision OV5640 image sensor and can be used with ArduCAM shields and other platforms like Freescale i.MX6 develop board.

The OV5640 (color) image sensor is a low voltage, high-performance, 1/4-inch 5 megapixel CMOS image sensor that provides the full functionality of a single chip 5 megapixel (2592x1944) camera using OmniBSI™ technology in a small footprint package. It provides full-frame, sub-sampled, windowed or arbitrarily scaled 8-bit/10-bit images in various formats via the control of the Serial Camera Control Bus (SCCB) interface.

The OV5640 has an image array capable of operating at up to 15 frames per second (fps) in 5 megapixel resolution with complete user control over image quality, formatting and output data transfer. All required image processing functions, including exposure control, gamma, white balance, color saturation, hue control, defective pixel canceling, noise canceling, etc., are programmable through the SCCB interface or embedded microcontroller. The OV5640 also includes a compression engine for increased processing power. In addition, Omnivision image sensors use proprietary sensor technology to improve image quality by reducing or eliminating common lighting/electrical sources of image contamination, such as fixed pattern noise, smearing, etc., to produce a clean, fully stable, color image.

2 Features

- 1.4 μm x 1.4 μm pixel with OmniBSI technology for high performance (high sensitivity, low crosstalk, low noise, improved quantum efficiency)
- optical size of 1/4"
- automatic image control functions: automatic exposure control (AEC), automatic white balance (AWB), automatic band filter (ABF), automatic 50/60 Hz luminance detection, and automatic black level calibration (ABLC)
- programmable controls for frame rate, AEC/AGC 16-zone size/position/weight control, mirror and flip, cropping, windowing, and panning
- image quality controls: color saturation, hue, gamma, sharpness (edge enhancement), lens correction, defective pixel canceling, and noise canceling
- support for output formats: RAW RGB, RGB565/555/444, CCIR656, YUV422/420, YCbCr422, and compression
- support for video or snapshot operations
- support for LED and flash strobe mode
- support for internal and external frame synchronization for frame exposure mode
- support for horizontal and vertical sub-sampling, binning
- support for minimizing artifacts on binned image
- support for data compression output
- support for anti-shake
- standard serial SCCB interface
- digital video port (DVP) parallel output interface and dual lane MIPI output interface
- embedded 1.5V regulator for core power
- programmable I/O drive capability, I/O tri-state configurability
- support for black sun cancellation
- support for images sizes: 5 megapixel, and any arbitrary size scaling down from 5 megapixel
- support for auto focus control (AFC) with embedded AF VCM driver
- embedded microcontroller
- suitable for module size of 8.5 x 8.5 x <6mm with both CSP and RW packaging

3 Key Specifications

- **active array size:** 2592 x 1944
- **power supply:**
 - core: 1.5V \pm 5% (with embedded 1.5V regulator)
 - analog: 2.6 ~ 3.0V (2.8V typical)
 - I/O: 1.8V / 2.8V
- **power requirements:**
 - active: TBD
 - standby: TBD
- **temperature range:**
 - operating: -30°C to 70°C (see [table 8-1](#))
 - stable image: 0°C to 50°C (see [table 8-1](#))
- **output formats:** 8-/10-bit RGB RAW output
- **lens size:** 1/4"
- **lens chief ray angle:** 24° (see [figure 10-2](#))
- **input clock frequency:** 6~27 MHz
- **S/N ratio:** TBD
- **dynamic range:** TBD
- **maximum image transfer rate:**
 - QSXGA (2592x1944): 15 fps
 - 1080p: 30 fps
 - 1280x960: 45 fps
 - 720p: 60 fps
 - VGA (640x480): 90 fps
 - QVGA (320x240): 120 fps
- **sensitivity:** TBD
- **shutter:** rolling shutter / frame exposure
- **maximum exposure interval:** 1964 x t_{ROW}
- **pixel size:** 1.4 μm x 1.4 μm
- **well capacity:** TBD
- **dark current:** TBD
- **fixed pattern noise (FPN):** TBD
- **image area:** 3673.6 μm x 2738.4 μm
- **package dimensions:** 5985 μm x 5835 μm

4 Block Diagram

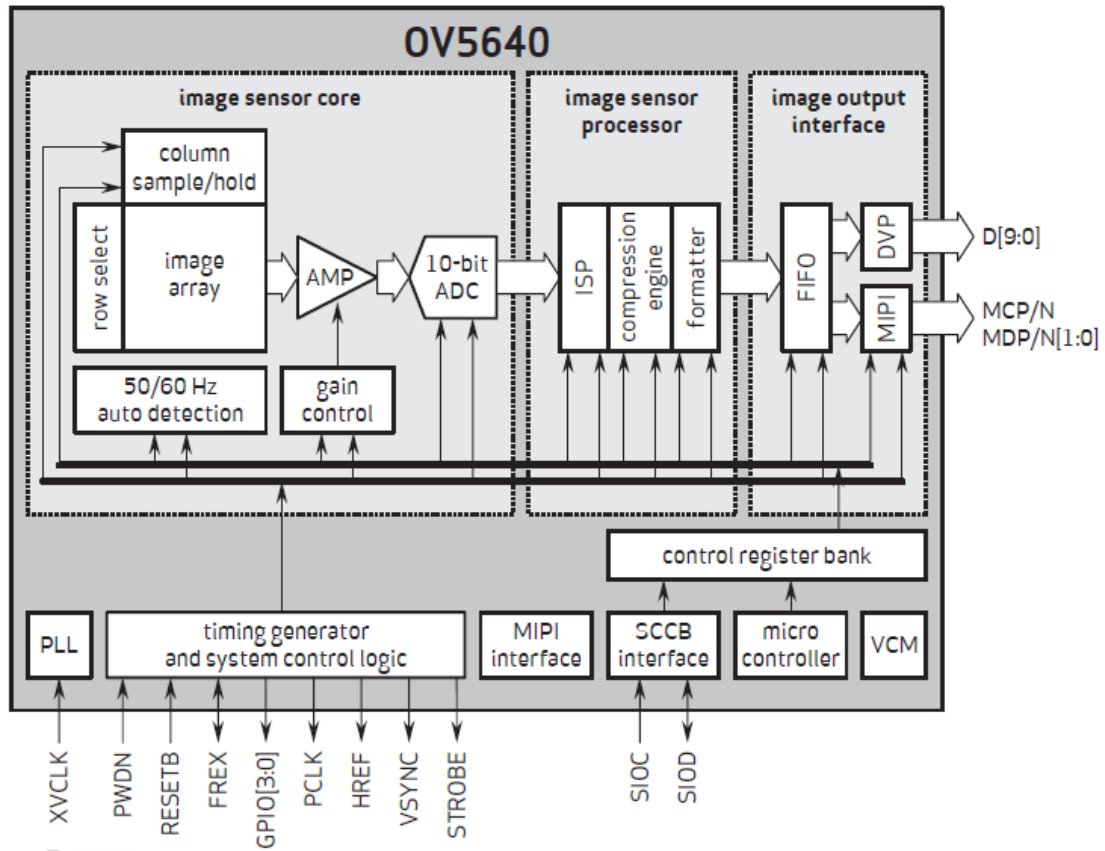

5 Application

- Cellular phones
- PDAs
- Toys
- Other battery-powered products
- ARM based platforms

6 Product Pictures

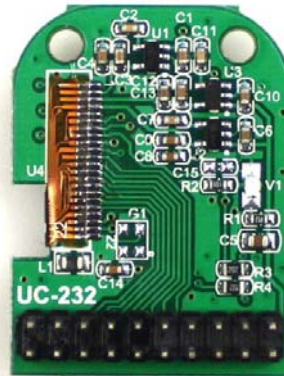

7 Pin Definition

The OV5640 module uses standard ArduCAM camera pin out. And the OV5640 support both DVP (parallel) and MIPI interface with some shared pins. User can configure the module with different interface mode and pin out definition is list as follows.

DVP interface

| Pin No. | PIN NAME | TYPE | DESCRIPTION |
|---------|----------|----------------|---|
| 1 | VCC | POWER | 3.3v Power supply |
| 2 | GND | Ground | Power ground |
| 3 | SCL | Input | Two-Wire Serial Interface Clock |
| 4 | SDATA | Bi-directional | Two-Wire Serial Interface Data I/O |
| 5 | VSYNC | Output | Active High: Frame Valid; indicates active frame |
| 6 | HREF | Output | Active High: Line/Data Valid; indicates active pixels |
| 7 | PCLK | Output | Pixel Clock output from sensor |
| 8 | XCLK | Input | Master Clock into Sensor |
| 9 | DOUT9 | Output | Pixel Data Output 9 (MSB) |
| 10 | DOUT8 | Output | Pixel Data Output 8 |
| 11 | DOUT7 | Output | Pixel Data Output 7 |
| 12 | DOUT6 | Output | Pixel Data Output 6 |
| 13 | DOUT5 | Output | Pixel Data Output 5 |
| 14 | DOUT4 | Output | Pixel Data Output 4 |
| 15 | DOUT3 | Output | Pixel Data Output 3 |
| 16 | DOUT2 | Output | Pixel Data Output 2 (LSB) |
| 17 | M+ | POWER | Power for VCM |
| 18 | GND | Ground | Ground for VCM |
| 19 | RST | Input | Sensor reset signal, active low |
| 20 | PWDN | Input | Power down input, active high |

MIPI interface

| Pin No. | PIN NAME | TYPE | DESCRIPTION |
|---------|----------|----------------|------------------------------------|
| 1 | VCC | POWER | 3.3v Power supply |
| 2 | GND | Ground | Power ground |
| 3 | SCL | Input | Two-Wire Serial Interface Clock |
| 4 | SDATA | Bi-directional | Two-Wire Serial Interface Data I/O |
| 5 | VSYNC | Output | NA |
| 6 | HREF | Output | NA |
| 7 | PCLK | Output | NA |
| 8 | XCLK | Input | Master Clock into Sensor |
| 9 | DOUT9 | Output | MIPI port MDP1 |
| 10 | DOUT8 | Output | MIPI port MDN1 |
| 11 | DOUT7 | Output | MIPI port MCP |
| 12 | DOUT6 | Output | MIPI port MCN |
| 13 | DOUT5 | Output | MIPI port MDP0 |

| | | | |
|----|-------|--------|---------------------------------|
| 14 | DOUT4 | Output | MIPI port MDN0 |
| 15 | DOUT3 | Output | NA |
| 16 | DOUT2 | Output | NA |
| 17 | M+ | POWER | Power for VCM |
| 18 | GND | Ground | Ground for VCM |
| 19 | RST | Input | Sensor reset signal, active low |
| 20 | PWDN | Input | Power down input, active high |

8 Mechanical Dimension

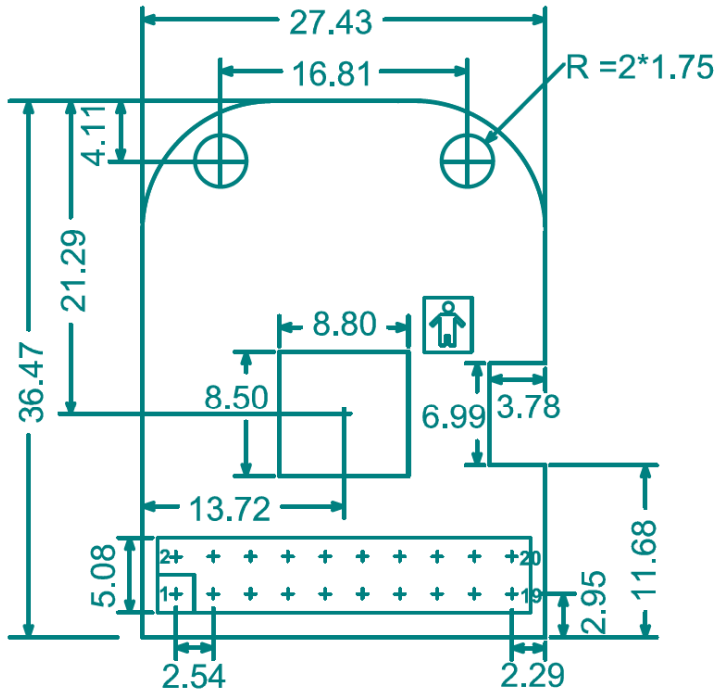

All dimensions are in mm